

Pionite® Resobak is a single-ply backing sheet that can be applied to a substrate faced with high pressure decorative laminate. With proper application, Resobak will help to provide dimensional stability to the assembly, reducing the likelihood of warpage. Resobak sheets are available in either brown or black. A slight variation in color is normal and should be anticipated. Resobak sheets are not sanded.

Product Description

Resobak is manufactured by saturating a kraft paper with resin followed by a high temperature curing process.

Standard Nominal Sizes

Type*	Thickness	Width	Length**
QYACR175 (in)	0.018	31"-50"-62"	Up to 12 feet
(mm)	0.45	787, 1270, 1575	Up to 3658 mm
QYBCR175 (in)	0.018	31"-50"-62"	Up to 12 feet
(mm)	0.45	787, 1270, 1575	Up to 3658mm

*QYA is brown, QYB is black

**Also available in rolls

Typical Uses

Resobak sheets applied to substrates faced with Pionite® high pressure decorative laminate help impart stability and reduce the likelihood of warpage of the final product. Resobak sheets are used in applications where the warpage control does not require the full balancing effect of a high pressure backer. Applications include table bottoms, cabinet interiors, and architectural panels.

Fabrication Tips

When working with Resobak sheets, these techniques will promote a quality application.

1. Proper conditioning of the laminate, substrate, and Resobak sheet minimizes possible warping, shrinking, or expansion of assembled panels. Ideally, all components should be conditioned at 70° F to 75° F (21° C to 25° C) and 45 to 50 percent relative humidity for 48 hours prior to assembly.
2. Always bond Resobak to a suitable substrate such as medium to high density fiberboard, particleboard, or metals.
3. When bonding Resobak with PVA glues, use less glue on the Resobak than used on the high pressure laminate.

4. Always lay up the Resobak with the grain running in the same direction as the high pressure laminate grain. Failure to match up grain directions could result in warpage of the final product.
5. Resobak is intended for interior use only, and should not be exposed to extreme humidity, continuous sunlight, or temperatures above 275° F (135° C) for extended periods of time.

Typical 3-Ply Construction

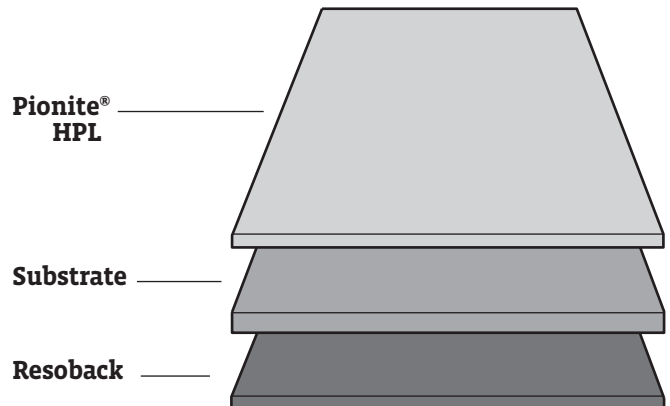

Technical Information

Physical Properties	Typical Resobak Values	Typical Pionite® Values B20
Nominal Thickness (in)	0.02	0.02
(mm)	0.5	0.5
Water Absorption*	51%	16%
Tensile Strength MD (psi)	4720	19700
Tensile Strength CD (psi)	2870	11000
Volatile Content	2 - 4%	N/A
Dimensional Stability MD**	0.50%	N/A
Dimensional Stability CD**	0.55%	N/A

* Weight increase after 2 hour immersion in water, at room temperature.

**Tested according to NEMA LD3-2000, Section 3.11.

Limited Warranty

Subject to the limitations set forth below, Panolam® Industries International Inc. (Panolam) expressly warrants that our products are reasonably free of defects in material and workmanship, and when properly handled and fabricated will conform, within accepted tolerances, to applicable manufacturing specifications as set forth in our technical brochure. This warranty shall extend to the original buyer for a period of twelve (12) months from the date of shipment of this product by Panolam, and shall not be assignable by the original buyer. This warranty does not cover damage resulting from accident, misuse, alteration, abuse or lack of reasonable care.

Due to the variety of uses and applications to which this product may be put, and because the manufacturer has no control over the end products fabricated, the warranty set forth above is exclusive and in lieu of all warranties, expressed or implied, in fact or by operation of law or otherwise, or arising by course of dealing or performance, custom or usage in the trade, including, without limitation, the implied warranties of fitness for a particular purpose and merchantability, and Panolam shall have no obligation or liability to any person or entity in connection with or arising from the furnishing, sale, installation or repair, use or subsequent sale of any product supplied by it.

Our maximum liability arising out of the sale of the products or their use, whether based upon warranty, contract, tort or otherwise, shall not exceed the actual payments received by us in connection therewith. In no event shall we be liable for special, incidental or consequential damages, including, but not limited to, arising hereunder or from the loss of profits, or loss of use damages, sales of the products.

Headquarters

Panolam® Industries International, Inc.

20 Progress Drive

Shelton, CT 06484

1-877-726-6526

www.panolam.com



© 2016 Panolam Industries International, Inc.